

# MT8 PRO SERIES (ATEX) MEDIUM PRESSURE METERING

Maximum Flow Rate: 30.28 L/hr (8.00 US gph)  
Minimum Flow Rate: 0.227 L/hr (0.06 US gph)  
Maximum Pressure: 241 bar (3500 psi) for  
Metallic Pump Heads

## **WANNER™** HYDRA-CELL® PRO METERING PUMP SOLUTIONS



*MT8 Medium Pressure Metering Pump with Stainless Steel pump head for use in ATEX/hazardous areas.*

### A higher standard of metering performance and energy efficiency.

- ATEX Zone 1 IIC T4 (dependant on pump configuration).
- Integrates **Wanner Hydra-Cell® Pro** seal-less pump technologies for the highest levels of volumetric and energy efficiencies across the full turndown – from 100% to 1% of rated flow – for accurate metering performance.
- Multiple diaphragms deliver a very low-pulse flow, eliminating pulsation dampeners and pipe strain in most applications, with reduced acceleration head losses and a wider process window.
- Patented ADPC (Advanced Diaphragm Position Control) protects diaphragms under closed or restricted inlet conditions.
- Exceeds API 675 standards for steady-state accuracy ( $\pm 1\%$ ), linearity ( $\pm 3\%$ ), and repeatability ( $\pm 3\%$ ) over a wide adjustable range.
- Hydraulic oil management system replenishes on every back stroke, ensuring superior accuracy and reliable operation at low- and high-suction pressures.
- Valve set design and material options reliably handle a wide range of viscosities and shear sensitivities, plus corrosive liquids, abrasives, slurries and suspended solids.
- Pumped liquid is 100% contained, preventing degradation and contamination.
- Reduced ownership costs in acquisition, operation, service, maintenance and energy use – with a 20+ year design life.



## Maximum Flow at Designated Pressure

for Pumps with Gearbox Reducer

**For Synchronous Speed, Self-cooled Motors** Liters per Hour (L/hr) Maximum Flow at Designated Pressure

All Pumps (L/hr)							Motor rpm	Gear Ratio	Pump rpm	1500	Required Motor kW	Motor frame
24 bar	34 bar	103 bar	172 bar	241 bar								
1.79**	1.79**	1.62**	1.47**	1.30**	18.42	81.45						
2.71	2.70	2.44	2.22	1.96**	27.76	54.03						
3.53	3.53	3.18	2.90	2.56	36.27	41.36						
4.72	4.70	4.25	3.87	3.41	48.39	31.00						
7.18	7.16	6.46	5.89	5.19	73.64	20.37						
14.93	14.89	13.44	12.25	10.80	153.22	9.79					0.12	IEC 63, B5
20.65	20.59	18.59	16.94	14.94	211.86	7.08					0.18	IEC 63, B5
31.64*	31.56*	28.49	25.96	22.89	324.68	4.62					0.25	IEC 71, B5
38.57*	38.47*	34.73*	31.65*	27.90	395.78	3.79					0.37	IEC 71, B5

**For 10:1 Turndown, Self-cooled Motors** Liters per Hour (L/hr) Maximum Flow at Designated Pressure

All Pumps (L/hr)							Motor rpm	Gear Ratio	Pump rpm	1500	Required Motor kW	Motor frame
24 bar	34 bar	103 bar	172 bar	241 bar								
1.79**	1.79**	1.62**	1.47**	1.30**	18.42	81.45						
2.71	2.70	2.44	2.22	1.96**	27.76	54.03						
3.53	3.53	3.18	2.90	2.56	36.27	41.36						
4.72	4.70	4.25	3.87	3.41	48.39	31.00						
7.18	7.16	6.46	5.89	5.19	73.64	20.37						
14.93	14.89	13.44	12.25	10.80	153.22	9.79					0.12	IEC 63, B5
20.65	20.59	18.59	16.94	14.94	211.86	7.08					0.18	IEC 63, B5
31.64*	31.56*	28.49	25.96	22.89	324.68	4.62					0.25	IEC 71, B5
38.57*	38.47*	34.73*	31.65*	27.90	395.78	3.79					0.37	IEC 71, B5
											0.55	IEC 80, B5

**Please Note:** Systems vary. The MT8 pump must be calibrated once installed to ensure optimum performance. The API 675 Performance Standard is achievable for flow rates as low as 0.227 L/hr (0.06 US gph). Please contact Wanner for assistance.

\* Flow rates above 30.28 lph are not guaranteed to meet API 675 Performance Standards.

\*\* Please consult Wanner for higher ratio gearboxes and flows below 2.2 L/hr.

### Notes:

1. The motor kW are based on ambient temperature conditions up to 25°C. For ambient temperatures above 25°C, Force-cooled Motors may be required. Please contact Wanner International.
2. Contact Wanner for performance specifications.
3. Based on using IE3 motors.
4. Maximum continuous motor speed is 1500 rpm at full pressure.
5. For intermittent or reduced pressure duties, please contact Wanner International.

**Manual Adjustment Controller** All Min/Max flow rates in Liters per Hour (L/hr)

24 Bar		34 Bar		103 Bar		172 Bar		241 Bar		Max Pump RPM	Required Motor kW and Frame Sizing
Min	Max	Min	Max	Min	Max	Min	Max	Min	Max		
0.23	38.00	0.23	37.91	0.23	34.22	0.23	31.18	/	/	390	0.37kW / IEC80 / B14 / 6-pole
/	/	/	/	/	/	/	/	0.23	27.50	390	0.55kW / IEC 80 / B14 / 6-Pole

Due to the Wanner Engineering Continuous Improvement Program, specifications and other data are subject to change.

## Pump Features

- Patented ADPC – Advanced diaphragm position control. Protects the diaphragms from adverse suction conditions.
- Can run dry indefinitely without damage to the pump.
- Wide, controllable flow range Independent of discharge pressure – from 100% to 1% of rated flow.
- Easy pump control eliminates mechanical actuators.
- Patented hydraulic replenishment systems replenishes on every diaphragm back stroke ensuring accurate consistent displacement on every forward stroke.
- Low shear pumping action.
- Internal pressure relief valve to protect the pump.
- Constant diaphragm stroke length ensures accurate control of flow rate with turn downs higher than 10:1
- Many materials of construction, easy change of parts makes pump repurposing easy.
- Compact design with oil management system and multiple diaphragms in a single pump head – reduces size and weight.
- Simple servicing, no special tools or equipment needed.
- Robust 20+ year service life with minimal maintenance.

## Pump Data

<b>Diaphragms per Liquid End</b>	3
<b>Flow Control</b>	Electronic variable speed drive
<b>Maximum Discharge Pressure</b>	
Metallic Heads:	241 bar (3500 psi)
<b>Maximum Inlet Pressure</b>	
Metallic Heads:	34 bar (500 psi)
<b>Operating Temperatures (min./max.)</b>	
Metallic Heads:	4.4°C (40°F) to 121° (250°F)
<i>Consult Wanner for temperatures outside this range</i>	
<b>Inlet Port</b>	1/4 inch NPT or BSPT
<b>Diaphragm Material Temperatures (min./max.)</b>	
4.4°C (40°F) to 121°C (250°F)	
<b>Discharge Port</b>	1/4 inch NPT or BSPT
<b>Maximum Solids Size</b>	200 microns
<b>Shaft Rotation</b>	Bi-directional
<b>Oil Capacity</b>	1.7 liters (1.75 US quarts)
<b>Suction Lift Capability</b>	6.1 meters (20 feet)
<b>Weight (less motor)</b>	
MT8 with Inline Gearbox:	53 kg
MT8 with Manual Adjustment:	55 kg

Due to the Wanner Engineering Continuous Improvement Program, specifications and other data are subject to change.

# MT8 Pro Medium Pressure (ATEX) | Representative Drawings

## Metallic Pump Heads Inches (mm)

**MT8 Pro Medium Pressure (ATEX)  
with Manual-Adjust**

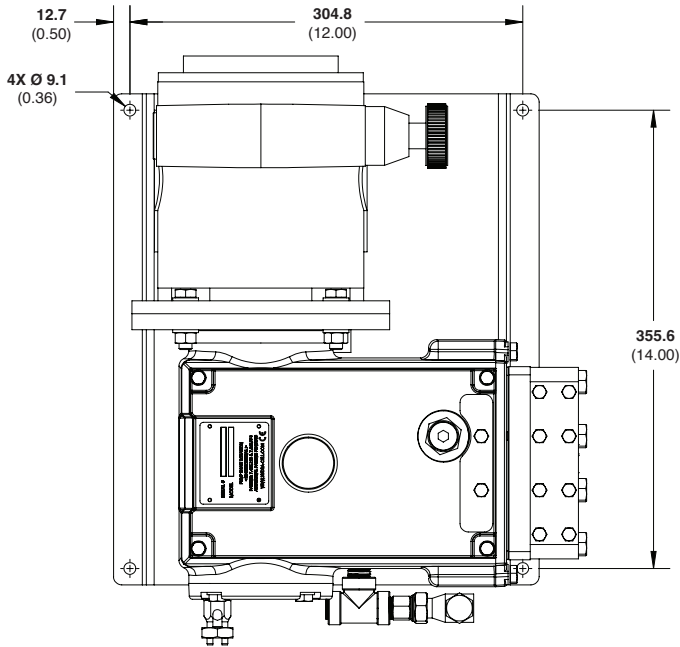

**MT8 Pro Medium Pressure (ATEX)  
with Fixed-Ratio Gearbox Reducer**

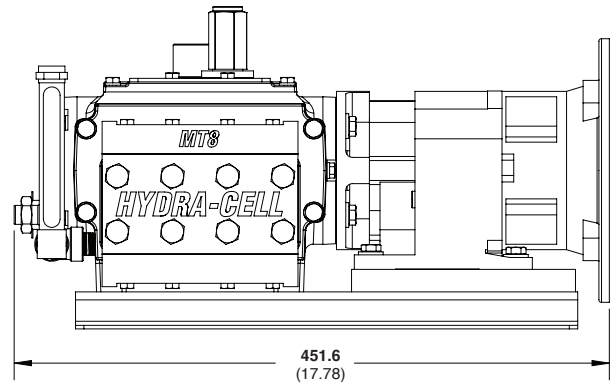
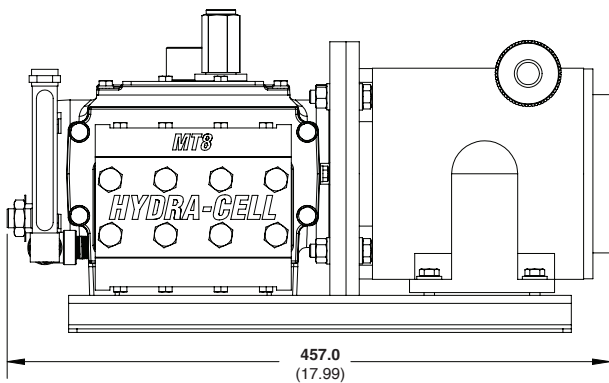
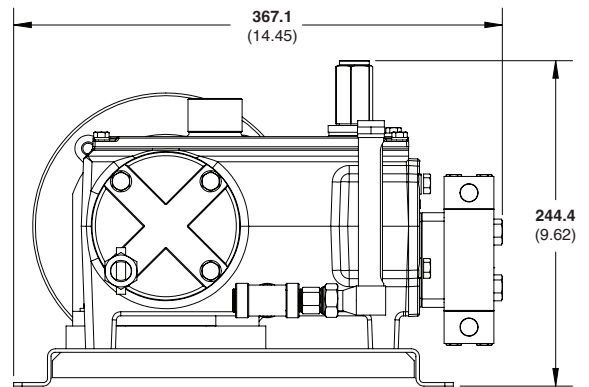
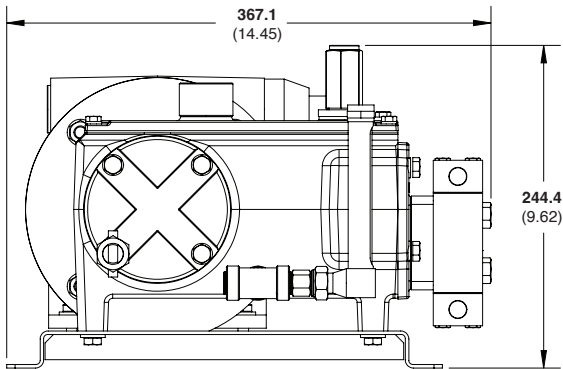
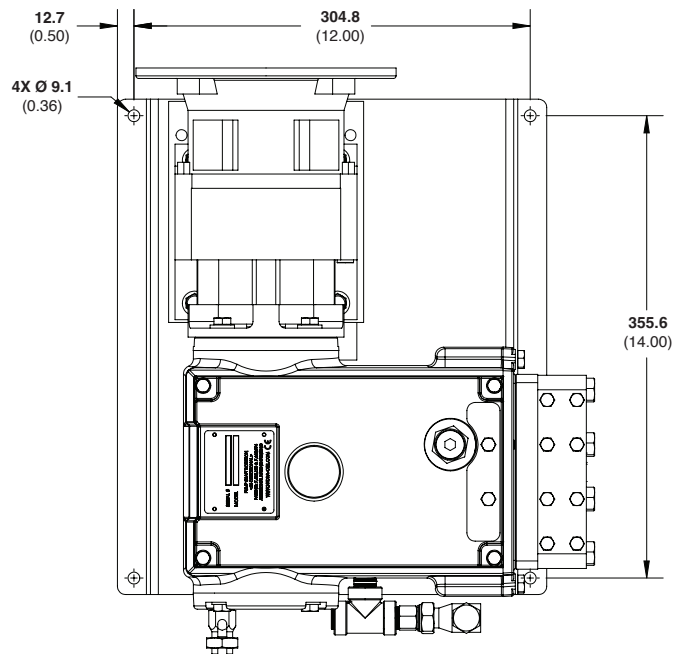

**Note:** Dimensions are for reference only. Contact Wanner for certified drawings.

## Metallic Pump Heads Inches (mm)

### MT8 Pro Medium Pressure (ATEX) Solution for Local and Remote Control

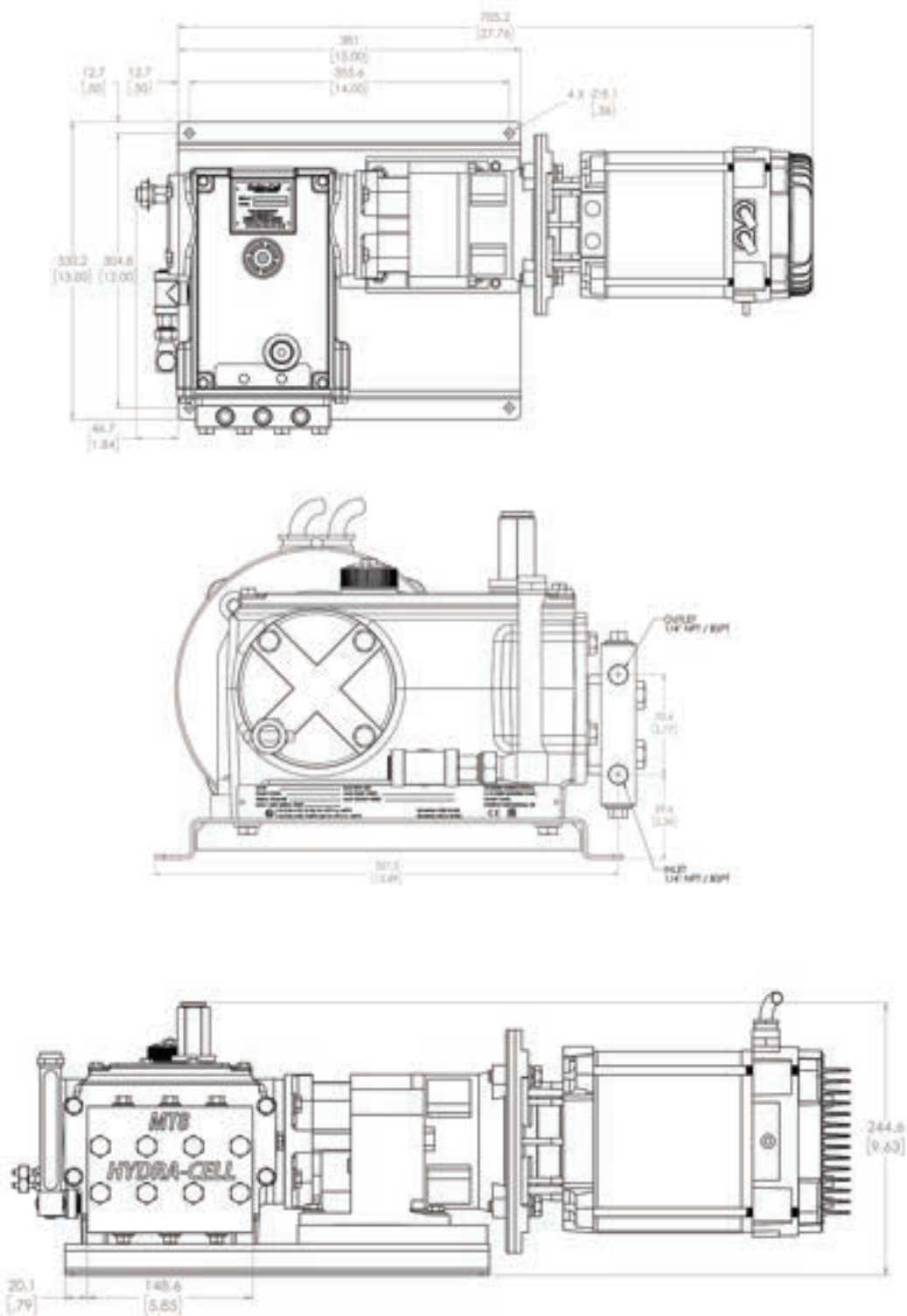

**Note:** Dimensions are for reference only. Contact Wanner for certified drawings.



## Metering and Dosing Control Options for use in ATEX/hazardous areas

### Electronic Flow Rate Adjustment Solution for Local or Remote Control

- Quick and precise flow rate control with versatile configurations
- High efficiency and reliability for heavy duty usage; up to 1500 rpm
- Remote control via 4-20mA input signal
- Local speed control via rotary potentiometer
- Max. pressure 172 bar with 3.79:1 Gearbox Ratio
- ATEX Zone 1 IIB T4

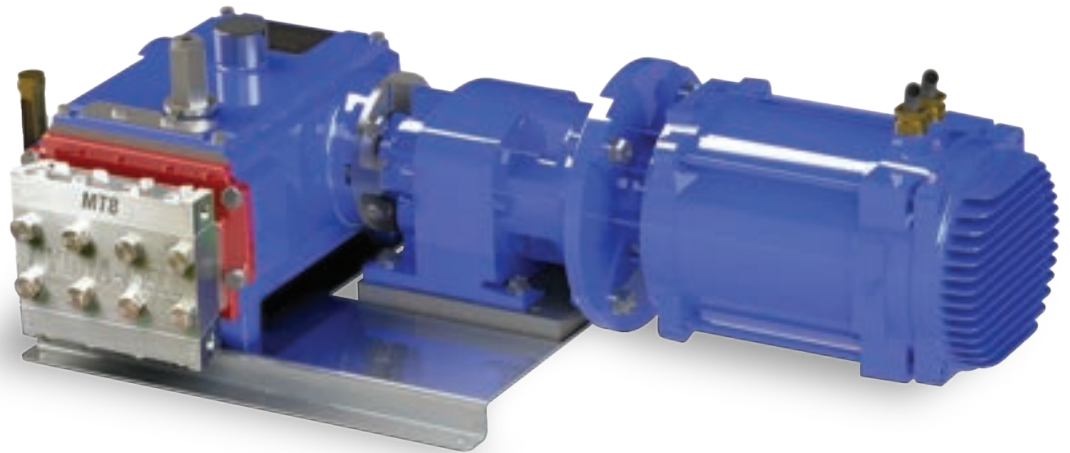

### Manual Flow Rate Adjustment for Local Control

- Linear fine adjustment scale on hand-wheel
- High reliability due to frictionless design
- Option to fit a mechanical lock to prevent unauthorised flow rate change
- ATEX Zone 1 IIC T4

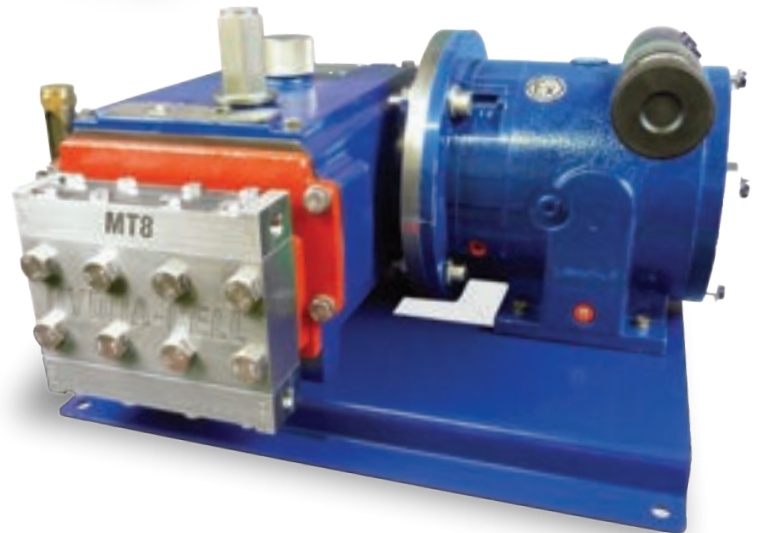

## Accessories, Options & Services

Consult Wanner International for complete details about available accessories and options as well as special services.

- Different Gearbox Ratios
- Actuating Oils
- Magnetic Drain Plug
- Motors (ATEX certified)
- Calibration Cylinders
- Back Pressure Valves
- Pressure Relief Valves
- API 675 Performance Test Certificate
- System Components, Priming Kits and Plugs
- Replacement Part Kits and Tool Kits
- Pulsation Dampeners
- Customisation Services

# MT8 Pro Medium Pressure (ATEX) | How to Order

## Ordering Information

A complete pump order number contains 18 digits based on the specified pump materials listed below:

1	2	3	4	5	6	7	8	9	10	11	12	13	14	15	16	17	18
M	T	0	8				J	N							T	M	

Digit	Order Code	Description
1-2	MT	<b>Pump Model Size</b> Triplex Metering Pumps
3-4	08	<b>Pump Capacity</b> 0.06 – 8.00 US gph (0.227 – 30.28 lph)
5	B F	<b>Pump Version</b> BSPT Ports; ATEX Zone 1 NPT Ports; ATEX Zone 1
6-7	AN SN TN	<b>Pump Head</b> Alloy 20 316 SST Hastelloy C
8	J	<b>Diaphragm</b> PTFE
9	N	<b>Leak Detection Style</b> No leak detection
10-11	AA SS TT	<b>CV Ball/Seat</b> Alloy 20 / Alloy 20 316 SST / 316 SS Hastelloy C / Hastelloy C
12	B G K	<b>Hydraulic End Oil</b> EPDM oil (NSF H1 accredited) 5W30 (Synthetic oil) Food-contact oil (NSF H1 accredited)
13	C D E M	<b>Motor Flange Size</b> IEC 63 B5 IEC 71 B5 IEC 80 B5 IEC 80 B14 (MX only)

Digit	Order Code	Description
14-15		<b>Gearbox Ratio</b>
	81	81.45:1
	54	54.03:1
	41	41.36:1
	31	31.00:1
	20	20.37:1
	10	9.79:1
	07	7.08:1
	05	4.62:1
	04	3.79:1*
	MX	Manual adjustment ATEX (specify M flange for this option)
16	T	<b>Baseplate</b> SST
17	M	<b>Maximum Pressure Rating</b> Medium Pressure 241 Bar (3500 psi)
18	L R X	<b>Electronic Flow Rate Adjustment Solution</b> Local speed control rotary potentiometer* Remote control 4-20mA input signal* Not Required**

\* Digit 18 options L and R: ATEX Zone 1 IIB T4  
Max pressure 172 Bar with 3.79 Gearbox Ratio (Digit 14-15 option 04)

\*\* Digit 18 option X: ATEX Zone 1 IIC T4

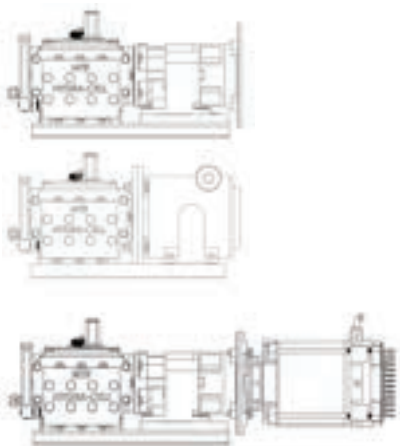

### MT8 Pro Low Pressure (ATEX) with fixed ratio gearbox:

Select configuration from digits 1-18.  
Do not select "M" (digit 13).  
Do not select "MX" (digits 14-15).

### MT8 Pro Low Pressure (ATEX) with manual adjust gearbox:

Select configuration as required digits 1-18.  
Select "M" (digit 13).  
Select "MX" (digits 14-15).

### MT8 Pro Low Pressure (ATEX) solution for local and remote control:

Select configuration as required digits 1-18.  
Select "E" (Digit 13).  
Do not select "MX" (digits 14-15).  
Select configuration as required for digit 18.

## Partners in over 70 countries



Global Sales and Technical Support

### Americas

- Minneapolis, Minnesota USA
- Wichita Falls, Texas USA
- São Paulo, Brazil
- Buenos Aires, Argentina

### EMEA | Australia

- Hampshire, United Kingdom
- Cairo, Egypt
- Düsseldorf, Germany
- Lyon, France

### Asia | Pacific

- Kowloon, Hong Kong
- Shanghai, China
- Jakarta, Indonesia

### India

- Mumbai, India
- New Delhi
- Bangalore
- Gujarat

## Wanner worldwide

GLOBAL SALES & TECHNICAL SUPPORT

### WANNER ENGINEERING, INC.

WORLD HEADQUARTERS & MANUFACTURING

Minneapolis, Minnesota USA  
t: 612-332-5681  
e: sales@wannereng.com  
Hydra-Cell.com

### REGIONAL OFFICE

Wichita Falls, Texas USA  
t: 940-322-7111  
e: sales@wannereng.com

### LATIN AMERICAN OFFICE

São Paulo, Brazil  
t: +55 (11) 99582-1969  
e: mmagoni@wannereng.com  
Hydra-Cell-Pumps.com.br

### WANNER INTERNATIONAL, LTD.

UNITED KINGDOM

Church Crookham,  
Hampshire UK GU52 8BF  
t: +44 (0) 1252 816847  
e: support@wannerint.com  
Hydra-Cell.co.uk

### WANNER PUMPS, LTD.

Kowloon, HONG KONG

t: +852 3428 6534  
e: sales@wannerpumps.com  
WannerPumps.com

Shanghai, CHINA

t: +86-21-6876 3700  
e: sales@wannerpumps.com  
WannerPumps.com

### WANNER INDIA PVT. LTD.

Mumbai, INDIA

t: +91 (22) 22044766  
e: support@wannerindia.com  
WannerIndia.com



**OFFICIAL UK  
DISTRIBUTOR**

Michael Smith Engineers Limited  
Web: www.michael-smith-engineers.co.uk  
Email: info@michael-smith-engineers.co.uk  
Freephone: 0800 316 7891

